

Welded, Hermetically Sealed Load Cell

FEATURES

- Capacities: 5–500 kg
- Stainless steel construction
- OIML R60 and NTEP approved
- IP68 protection
- **Optional**
 - FM Approval, ATEX, IECEx and UKCA certifications available.



MAIN APPLICATIONS

- Low-profile platforms
- Loss-in-weight feeders
- Marine and hybrid scales
- Belt weighers
- Demanding food industry environments

DESCRIPTION

Model 355 is a welded bending load cell manufactured in stainless steel. It is hermetically sealed against moisture and has a polyurethane shielded cable, enabling it to function in demanding environments while maintaining full operating specifications.



With its low profile, high accuracy and hermetic sealing, the Model 355 load cell is ideal for applications such as low-profile platforms, weighing and packing machines, conversion of mechanical and varied other applications where sealed cells are required. For hazardous environments, this load cell is available with FM Approval, ATEX, IECEx and UKCA certifications as an option.

Two additional sense wires feedback the voltage reaching the load cell. Complete compensation of change in the lead resistance, due to temperature change and/or cable extension, is achieved by feeding this voltage into the appropriate electronics.

DIMENSIONS (mm)

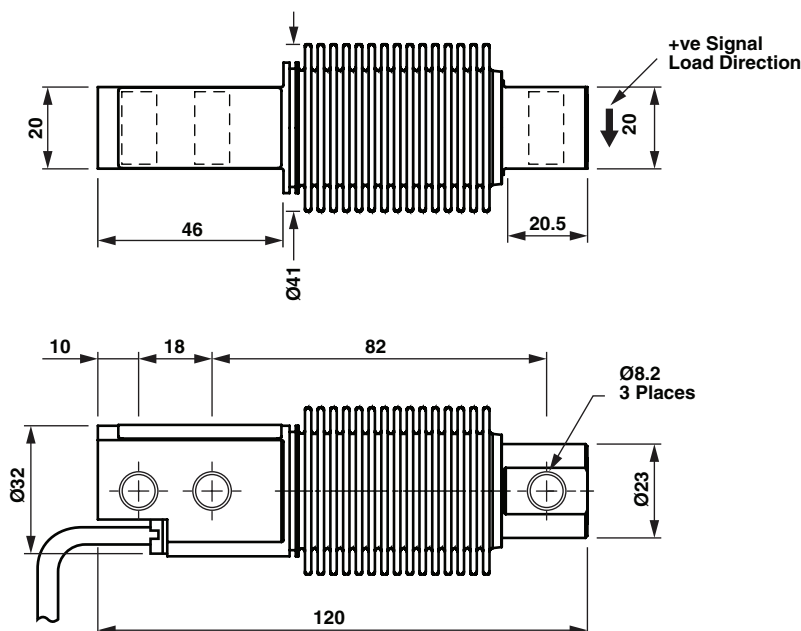

Welded, Hermetically Sealed Load Cell

SPECIFICATIONS					
PARAMETER	VALUE				UNIT
Rated capacity—R.C. (E _{max})	5, 10, 20, 30, 50, 100, 200, 250, 500				kg
NTEP/OIML accuracy class	NTEP	Non-Approved	C3 ⁽¹⁾	C4 ⁽²⁾	
Maximum no. of intervals (n)	4000 single	1000	3000	4000	
Y = E _{max} /V _{min}	5800	2000	15000	13333	Maximum available 15000
Rated output—R.O.	2.00 (UR matched = 2.02)				mV/V
Rated output tolerance	0.002				±mV/V
Zero balance	0.04				±mV/V
Zero return, 30 min.	0.0125	0.0500	0.0170	0.0125	±% of applied load
Total error	0.0200	0.05	0.0200	0.0150	±% of rated output
Temperature effect on zero	0.0023	0.007	0.0009	0.0011	±% of rated output/°C
Temperature effect on output	0.001	0.0040	0.0010	0.0008	±% of applied load/°C
Temperature range, compensated	-10 to +40				°C
Temperature range, safe	-20 to +70				°C
Maximum safe central overload	150				% of R.C.
Ultimate central overload	300				% of R.C.
Excitation, recommended	10				VDC or VAC RMS
Excitation, maximum	15				VDC or VAC RMS
Input impedance	380±10				Ω
Output impedance	355±5				Ω
Insulation resistance	>2000				MΩ
Cable length	3				m
Cable type	6-wire, braided, polyurethane, dual floating screen				Standard
Construction	Stainless steel				
Environmental protection	IP68				
Recommended torque	22.0				N*m

⁽¹⁾ 20% utilization

⁽²⁾ 30% utilization

All specifications subject to change without notice.

CERTIFICATION MARKINGS

ATEX, IECEX, UKEX MARKINGS (FOR ZONE 0,1,2 AND ZONE 20,21,22)

II 1 GD
Ex ia IIC T4 Ga
Ex ia IIIC T135°C Da
Ta = -20°C to +40/70°C

ATEX/UKEX markings (for Zone 2 and Zone 22 only)

II 3GD
Ex ec IIC T6 Gc
Ex tc IIIC T85°C Dc
Ta = -20 to +40°C

or
II 3GD
Ex ec IIC T4 Gc
Ex tc IIIC T135°C Dc
Ta = -20 to +70°C

FM Approval markings (USA and Canada)

IS Class I, II, III, Division 1,
Groups A, B, C, D, E, F and G; T4
Ta = -25°C to +40°C

Wiring Schematic Diagram

